

# ViewSonic®



---

## ViewPad 7e User Guide

---

**IMPORTANT:** Please read this User Guide to obtain important information on installing and using your product in a safe manner, as well as registering your product for future service. Warranty information contained in this User Guide will describe your limited coverage from ViewSonic Corporation, which is also found on our web site at <http://www.viewsonic.com> in English, or in specific languages using the Regional selection box in the upper right corner of our website. "Antes de operar su equipo lea cuidadosamente las instrucciones en este manual"

---

Model No. VS14359

# Compliance Information

## FCC Statement

The following statement applies to all products that have received FCC approval.

Applicable products bear the FCC logo, and/or an FCC ID in the format FCC ID: GSS-VS14359 on the product label. This device complies with part 15 of the FCC Rules.

Operation is subject to the following two conditions: (1) This device may not cause harmful interference, and (2) This device must accept any interference received, including interference that may cause undesired operation. This mobile device has been tested and found to comply with the limits for a Class B digital device, pursuant to Part 15 of the FCC Rules. These limits are designed to provide reasonable protection against harmful interference in a residential installation. This equipment generates, uses and can radiate radio frequency energy and, if not installed and used in accordance with the instructions, may cause harmful interference to radio communications. However, there is no guarantee that interference will not occur in a particular installation. If this equipment does cause harmful interference to radio or television reception, which can be determined by turning the equipment off and on, the user is encouraged to try to correct the interference by one or more of the following measures

- Reorient or relocate the receiving antenna.
- Increase the separation between the equipment and receiver.
- Connect the equipment into an outlet on a circuit different from that to which the receiver is connected.
- Consult the dealer or an experienced radio/TV technician for help.

Changes or modifications not expressly approved by the party responsible for compliance could void the user's authority to operate the equipment. The antenna(s) used for this transmitter must not be colocated or operating in conjunction with any other antenna or transmitter.

## FCC SAR information

FCC Radiation Exposure Statement

This equipment complies with FCC RF radiation exposure limits set forth in an uncontrolled environment. This transmitter must not be co-located or operating in conjunction with any other antenna or transmitter.

The device was tested and complies to measurement standards and procedures specified in FCC OE Bulletin 65, Supplement C

## Canada Statement

This device complies with Industry Canada licence-exempt RSS standard(s). Operation is subject to the following two conditions: (1) this device may not cause interference, and (2) this device must accept any interference, including interference that may cause undesired operation of the device.

## CE Conformity for European Countries

 The device complies with the EMC Directive 2004/108/EC and Low Voltage Directive 2006/95/EC, R&TTE Directive 1999/5/EC.

### **Please read before proceeding**

- Use only the batteries and power adapter provided by the manufacturer. The use of unauthorized accessories may void your warranty.
- Do not store your device in temperatures higher than 50°C (122°F).
- The operating temperature for this device is from 0°C (32°F) to 40°C (104°F).

### **CE SAR Information**

This device MEETS GUIDELINES FOR EXPOSURE TO RADIO WAVES. Your mobile device is a radio transmitter and receiver. It is designed not to exceed the limits for exposure to radio waves recommended by international guidelines. These guidelines were developed by the independent scientific organization ICNIR and include safety margins designed to assure the protection of all persons, regardless of age and health.

The exposure guidelines for mobile devices employ a unit of measurement known as the Specific Absorption Rate or SAR. The SAR limit stated in the ICNIRP guidelines is 2.0 W/kg averaged over 10 grams of tissue. Test for body worn SAR, the positions of the device are at a minimum of 1.5 cm from the body with the device transmitting at its highest certified power level in all tested frequency bands. The actual SAR level of an operating device can be below the maximum value because the device is designed to use only the power required to reach the network. That amount changes depending on a number of factors such as how close you are to a network base station. The highest SAR value under the ICNIRP guidelines for use of the device at the body is 0.0246 W/kg. Use of device accessories and enhancements may result in different SAR values. SAR values may vary depending on national reporting and testing requirements and the network band.

### **Following information is only for EU-member states:**

The mark is in compliance with the Waste Electrical and Electronic Equipment Directive 2002/96/EC (WEEE).



The mark indicates the requirement NOT to dispose the equipment including any spent or discarded batteries or accumulators as unsorted municipal waste, but use the return and collection systems available.



If the batteries, accumulators and button cells included with this equipment, display the chemical symbol Hg, Cd, or Pb, then it means that the battery has a heavy metal content of more than 0.0005% Mercury or more than, 0.002% Cadmium, or more than 0.004% Lead.



### **European Union Regulatory Conformance**

The equipment complies with the RF Exposure Requirement 1999/519/EC, Council Recommendation of 12 July 1999 on the limitation of exposure of the general public to electromagnetic fields (0-300 GHz). This equipment meets the following conformance standards: EN50332-1/2, EN301489-1, EN301489-17, EN55022/24, EN62209-2, EN60950-1, EN300328.



The device has been tested to comply with the Sound Pressure Level requirement laid down in the applicable EN 50332-1 and EN 50332-2 standards. Permanent hearing loss may occur if earphones or headphones are used at high volume for prolonged periods of time. A pleine puissance, l'écoute prolongée du baladeur peut endommager l'oreille de l'utilisateur. The conformity assessment procedure has been followed with the involvement of the following Notified Body: UL-CCS (Compliance Certification Services 0984)

Identification mark: CE0984 (UL-CCS) CE  0984 

This equipment may be operated in:							
AT	BE	BG	CH	CY	CZ	DE	DK
EE	ES	FI	FR	GB	GR	HU	IE
IT	IS	LI	LT	LU	LV	MT	NL
NO	PL	PT	RO	SE	SI	SK	TR

We, hereby, declare that this cellular, Wi-Fi, & Bluetooth radio is in compliance with the essential requirements and other relevant provisions of Directive 1999/5/EC.

#### Products with 2.4-GHz Wireless LAN Devices France

For 2.4-GHz wireless LAN operation of this product, certain restrictions apply. This equipment may use the entire-2400-MHz to 2483.5-MHz frequency band (channels 1 through 13) for indoor applications. For outdoor use, only 2400-2454 MHz frequency band (channels 1-9) may be used. For the latest requirements, see <http://www.art-telecom.fr>.

#### Caution:

Risk of explosion if battery replaced aced by an incorrect type.  
Dispose of used batteries according to the instructions.

RISK GROUP 1  
CAUTION

Possibly hazardous optical radiation emitted from this product. Do not stare at operating lamp. May be harmful to the eyes.

IEC 62471: 2006

## Important Safety Instructions

1. DO NOT place objects on top of the device, as objects may scratch the screen.
2. DO NOT expose the device to dirty or dusty environments.
3. DO NOT place the device on an uneven or unstable surface.
4. DO NOT insert any foreign objects into the device.
5. DO NOT expose the device to strong magnetic or electrical field.
6. DO NOT expose the device to direct sunlight as it can damage the LCD Screen. Keep it away from heat sources.
7. SAFE TEMPERATURE: This device should only be used in environments with ambient temperatures between 0°C and 40°C.
8. DO NOT use the device in the rain.
9. Please check with your Local Authority or retailer for proper disposal of electronic products.
10. The device and the adapter may produce some heat during normal operation or charging. To prevent discomfort or injury from heat exposure, DO NOT leave the device on your lap.
11. POWER INPUT RATING: Refer to the rating label on the device and be sure that the power adapter complies with the rating. Only use accessories specified by the manufacturer.
12. DO NOT use a pen or any sharp object to tap the screen.
13. Clean the touch screen with a soft cloth. If needed, dampen the cloth slightly before cleaning. Never use abrasives or cleaning solutions.
14. Always power off the device to install or remove external devices that do not support hot-plug.
15. Disconnect the device from an electrical outlet and power off before cleaning the device.
16. DO NOT disassemble the device. Only a certified service technician should perform repair.
17. The device has apertures to disperse heat. DO NOT block the device ventilation, the device may become hot and malfunction as a result.
18. Risk of explosion if battery replaced by an incorrect type. Dispose of used batteries according to the instructions.
19. Users have to use the connection to USB interfaces with USB 2.0 version or higher.
20. PLUGGABLE EQUIPMENT: the socket-outlet shall be installed near the equipment and shall be easily accessible.

## Declaration of RoHS Compliance

This product has been designed and manufactured in compliance with Directive 2002/95/EC of the European Parliament and the Council on restriction of the use of certain hazardous substances in electrical and electronic equipment (RoHS Directive) and is deemed to comply with the maximum concentration values issued by the European Technical Adaptation Committee (TAC) as shown below:

Substance	Proposed Maximum Concentration	Actual Concentration
Lead (Pb)	0.1%	< 0.1%
Mercury (Hg)	0.1%	< 0.1%
Cadmium (Cd)	0.01%	< 0.01%
Hexavalent Chromium (Cr <sup>6+</sup> )	0.1%	< 0.1%
Polybrominated biphenyls (PBB)	0.1%	< 0.1%
Polybrominated diphenyl ethers (PBDE)	0.1%	< 0.1%

Certain components of products as stated above are exempted under the Annex of the RoHS Directives as noted below:

Examples of exempted components are:

1. Mercury in compact fluorescent lamps not exceeding 5 mg per lamp and in other lamps not specifically mentioned in the Annex of RoHS Directive.
2. Lead in glass of cathode ray tubes, electronic components, fluorescent tubes, and electronic ceramic parts (e.g. piezoelectronic devices).
3. Lead in high temperature type solders (i.e. lead-based alloys containing 85% by weight or more lead).
4. Lead as an alloying element in steel containing up to 0.35% lead by weight, aluminium containing up to 0.4% lead by weight and as a copper alloy containing up to 4% lead by weight.

## Copyright Information

Copyright © ViewSonic® Corporation, 2011. All rights reserved.

Android is a trademark of Google Inc. Use of this trademark is subject to Google Permissions.

This product has an Android™ platform based on Linux, which can be expanded by a variety of JME-based application SW.

All products used in this device and trademarks mentioned herein are trademarks or registered trademarks of their respective owners.

Google™, the Google logo, Android™, the Android logo and Gmail™ are trademarks of Google Inc. Use of this trademark is subject to Google Permissions. Wi-Fi and the Wi-Fi CERTIFIED logo are registered trademarks of the Wireless Fidelity Alliance.

microSD™ is a trademark of SD Card Association.

Bluetooth and the Bluetooth logo are trademarks owned by Bluetooth SIG, Inc. Java, JME and all other Java-based marks are trademarks or registered trademarks of Sun Microsystems, Inc. in the United States and other countries.

The prediction engine of the input method is TOUCHPAL, provided by COOTEK. DataViz and RoadSync are registered trademarks of DataViz, Inc. All rights reserved. DataViz and Documents To Go are trademarks or registered trademarks of DataViz, Inc. All rights reserved.

Word To Go™, Sheet To Go®, Slideshow To Go®, PDF To Go® and icons are trademarks or registered trademarks of DataViz, Inc. All rights reserved.

Disclaimer: ViewSonic Corporation shall not be liable for technical or editorial errors or omissions contained herein; nor for incidental or consequential damages resulting from furnishing this material, or the performance or use of this product. In the interest of continuing product improvement, ViewSonic Corporation reserves the right to change product specifications without notice. Information in this document may change without notice.

No part of this document may be copied, reproduced, or transmitted by any means, for any purpose without prior written permission from ViewSonic Corporation.

### Intellectual Property Right Information

Right to all technologies and products that comprise this device are the property of their respective owners:

This product has an Android platform based on Linux, which can be expanded by a variety of Java-Script-based application SW.

Google, the Google logo, Android, the Android logo, Gmail, and YouTube are trademarks of Google Inc. Bluetooth and the Bluetooth logo are trademarks owned by Bluetooth SIG, Inc. Java, JME and all other Java-based marks are trademarks or registered trademarks of Sun Microsystems, Inc. in the United States and other countries. microSD is a trademark of SD Card Association. The prediction engine of the input method is TOUCHPAL, provided by COOTEK.

# Product Registration

To meet your future needs, and to receive any additional product information as it becomes available, please register your product on the Internet at: [www.viewsonic.com](http://www.viewsonic.com).

## For Your Records

<b>Product Name:</b>	ViewPad 7e
<b>Model Number:</b>	VS14359
<b>Document Number:</b>	ViewPad 7e_UG_ENG Rev. 1a 08-24-11
<b>Serial Number:</b>	_____
<b>Purchase Date:</b>	_____

### Product disposal at end of product life

ViewSonic respects the environment and is committed to working and living green. Thank you for being part of Smarter, Greener Computing. Please visit ViewSonic website to learn more.

USA & Canada: <http://www.viewsonic.com/company/green/recycle-program/>

Europe: <http://www.viewsoniceurope.com/uk/kbase/article.php?id=639>

Taiwan: <http://recycle.epa.gov.tw/recycle/index2.aspx>



# Features

1. Android 2.3 platform can be expanded with many third-party apps
2. TFT screen with 800x600 pixel resolution
3. Portrait and landscape viewing with G-Sensor rotation
4. 2 cameras for taking photos and recording videos
5. Android Launcher or ViewScene 3D view mode
6. Automatic brightness adjustment
7. Web browsing, instant messaging and e-mail
8. Built-in e-reader and online e-book store
9. Multi-language on-screen display

<b>Chapter 1: Getting Started</b> .....	<b>1</b>
<b>1.1 Your Device</b> .....	<b>1</b>
<b>1.2 Accessories</b> .....	<b>3</b>
<b>1.3 Installing Memory Card</b> .....	<b>3</b>
<b>1.4 Charging Battery</b> .....	<b>4</b>
<b>1.5 Using Headsets</b> .....	<b>4</b>
<b>1.6 Turning Device On or Off</b> .....	<b>5</b>
Turn device on or off.....	5
Set device to Silent mode.....	5
<b>1.7 Unlocking the Screen</b> .....	<b>5</b>
To Unlock the screen.....	5
 <b>Chapter 2: The Basics</b> .....	 <b>6</b>
<b>2.1 Home Screen</b> .....	<b>6</b>
Set Screen Mode.....	6
Extended Home Screen .....	6
Shortcut Icons .....	7
Widgets .....	8
Applications .....	8
Setting Wallpaper .....	9
<b>2.2 Entering Text</b> .....	<b>10</b>
On-Screen Keyboard.....	10
Setting Input Method .....	11
<b>2.3 Transferring Contents</b> .....	<b>11</b>
Making Connection.....	11
Transferring Your Data .....	12
 <b>Chapter 3: Using Email</b> .....	 <b>13</b>
<b>3.1 Setting up an Internet Email Account</b> .....	<b>13</b>
<b>3.2 Composing and Sending an Email</b> .....	<b>13</b>
<b>3.3 Receiving an Email</b> .....	<b>14</b>
 <b>Chapter 4: Using Internet</b> .....	 <b>15</b>
<b>4.1 Setting up Wi-Fi</b> .....	<b>15</b>
<b>4.2 Accessing the Web</b> .....	<b>16</b>

<b>Chapter 5: Using Bluetooth .....</b>	<b>17</b>
<b>5.1 Connecting to Bluetooth Devices .....</b>	<b>17</b>
<b>Chapter 6: Searching on Device .....</b>	<b>18</b>
<b>6.1 Searching Contents on Device.....</b>	<b>18</b>
<b>6.2 Searching the Web .....</b>	<b>18</b>
<b>Chapter 7: Multimedia Applications .....</b>	<b>19</b>
<b>7.1 Taking Photos and Videos .....</b>	<b>19</b>
Taking a Photo.....	19
Recording a Video.....	19
Configuring Camera Settings .....	19
<b>7.2 Playing Photos and Videos.....</b>	<b>20</b>
Viewing Photos .....	20
Playing Videos.....	20
<b>7.3 Playing Music.....</b>	<b>21</b>
Playing Music .....	21
Managing Playlist .....	21
<b>Chapter 8: Applications .....</b>	<b>22</b>
<b>8.1 Email .....</b>	<b>22</b>
<b>8.2 Browser .....</b>	<b>22</b>
<b>8.3 Camera .....</b>	<b>22</b>
<b>8.4 Music .....</b>	<b>22</b>
<b>8.5 Gallery .....</b>	<b>22</b>
<b>8.6 Sound Recorder.....</b>	<b>22</b>
<b>8.7 Amazon Kindle.....</b>	<b>22</b>
<b>8.8 Amazon Appstore .....</b>	<b>22</b>
<b>8.9 Amazon MP3 .....</b>	<b>22</b>
<b>8.10 Calculator.....</b>	<b>23</b>
<b>8.11 Calendar .....</b>	<b>23</b>
<b>8.12 Clock.....</b>	<b>23</b>
<b>8.13 Search.....</b>	<b>23</b>
<b>8.14 Downloads .....</b>	<b>23</b>
<b>8.15 ES File Explorer .....</b>	<b>23</b>

8.16 Alert Machine .....	23
8.17 Dropbox.....	23
8.18 Note Everything .....	23
8.19 Sketcher .....	24
8.20 Tunein Radio .....	24
8.21 Twitter .....	24
8.22 Settings .....	24
8.23 FW Update .....	24
<b>Chapter 9: Managing Your Device .....</b>	<b>25</b>
9.1 Wireless & networks.....	25
9.2 Sound .....	25
9.3 Display.....	25
9.4 Location & security .....	26
9.5 Applications .....	26
9.6 Accounts & sync.....	26
9.7 Privacy.....	26
9.8 Storage .....	27
9.9 Language & Keyboard .....	27
9.10 Voice input & output.....	27
9.11 Accessibility .....	27
9.12 Date & time .....	27
9.13 About device .....	27
<b>Specifications .....</b>	<b>28</b>

# Chapter 1: Getting Started

## 1.1 Your Device

### Front

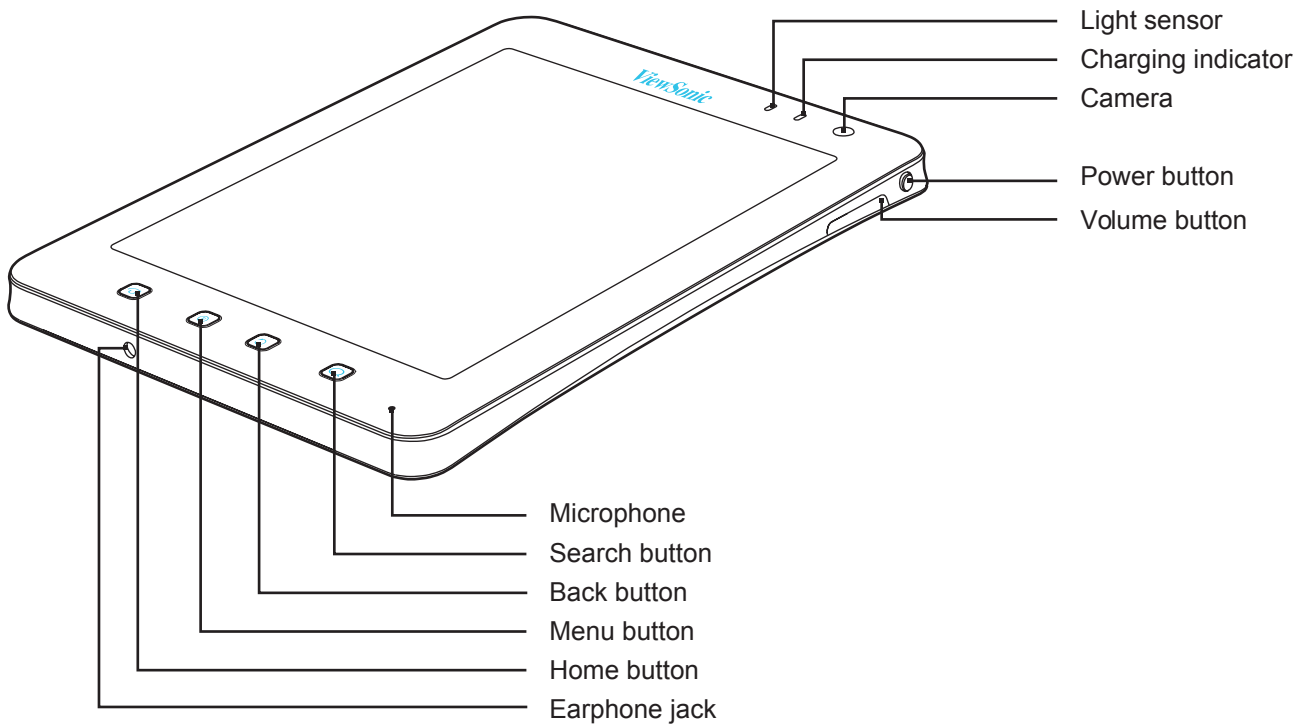

Part Name	Description
Light sensor	Auto-adjust the screen brightness for your eyes
Charging indicator	Light is red while charging and turns green when charging is completed
Camera	Take photos and record videos
Power button	Power on or off the device, put it to sleep, and wake it up
Volume button	Adjust the sound
Microphone	Voice input
Search button	Search the content or web page
Back button	Go back to the previous screen or menu
Menu button	Open the menu
Home button	Go back to the home screen

## Rear

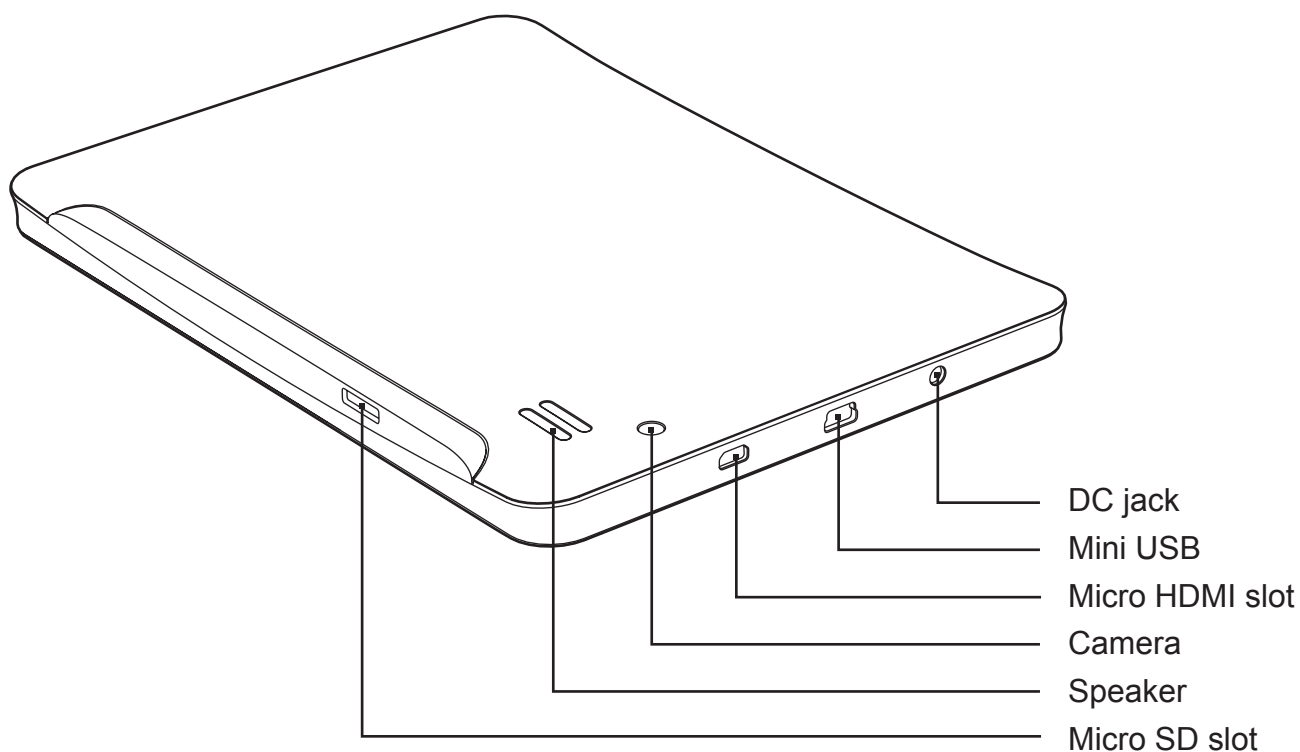

Part Name	Description
DC jack	Connect the AC power adapter
Mini USB port	Connect the USB cable
Micro HDMI port	Connect the HDMI cable
Camera	Take photos and record videos
Speaker	Audio output
Micro SD slo	Insert a Micro SD Memory Card

## 1.2 Accessories

Your package comes with the following items. If any of them is missing, please contact your retailer.

- ViewPad 7e
- AC adapter with US/EU/UK plug
- USB cable
- Quick Start Guide
- Safety Information

## 1.3 Installing Memory Card

You need a Micro SD card to store photo, music, videos and other data.

### To install the memory card

1. Insert the Micro SD card as shown. Make sure the golden contacts are facing down.

### To remove the memory card

1. For safe removal, tap  > **Settings**>**Storage**> **Unmount SD card**.
2. Use your finger to push the memory card out of card slot.

### NOTE



Do not remove the memory card while the device is turned on. Sudden removal of the memory card may cause data loss or unpredictable system hang up.

## 1.4 Charging Battery

When you first take your ViewPad out of the box, the battery is only partially charged. To fully charge the battery, charge it for 2 hours.

### Charge the battery

1. Connect one end of the AC adaptor to the DC jack on top of the device.
2. Plug the other end of the AC adaptor to the wall outlet to start charging.

When the battery is charging and the device is turned on, the  icon is displayed on the status bar. When the battery is fully charged, the  icon is displayed on the status bar.

### USB Charging

1. Power on your computer.
2. Plug the small end of the USB cable into the device's mini-USB port.
3. Plug the other end to your computer to start charging.

Your device has a charging indicator next to the front camera. While the device is turned on, the indicator light is red when charging and green when charging is complete.

### NOTE

- To prevent damage to your device, only use the supplied AC adapter.
- USB connected information will appear when you connect your device with computer.

## 1.5 Using Headsets

For listening to music, plug a headset to the headset jack.

### NOTE

- When using a headset, your ability to hear outside sounds may be limited. Do not use headset if it will endanger you.
- When using a headset, do not set the volume to its maximum as it may damage your hearing.



## 1.6 Turning Device On or Off

### Turn device on or off

After installing the memory card and charging the battery, the device is ready to be turned on.

### Turn on your device

Press and hold the **Power** button  on the left top of your device until the device display turns on.

### Turn off your device

1. Press and hold the **Power** button  until a pop-up window appears.
2. Tap **Power off**, and then select **OK** to confirm.

### To set your device to Sleep mode

To set the device to sleep mode, press the **Power** button . This will turn the display off. To turn the display on, press the **Power** button  again.



### Set device to Silent mode

1. Press and hold the **Power** button  until a pop-up window appears.
2. Tap **Silent mode**.

Or, on a locked screen, slide  to the left.

To undo silent mode, slide  to the left.



### NOTE

To press **Power** button  and **Home** button  at the same time for 3 seconds will reset the device.

## 1.7 Unlocking the Screen

Lock the screen to prevent it from accidentally being touched. By default, the screen locks after being idle for a period of time. You can set the length of screen timeout until the screen locks.

### To Unlock the screen

1. Press the **Power** button  to turn on the display from sleep mode.
2. Drag the  icon to the right to unlock the screen.

# Chapter 2: The Basics

## 2.1 Home Screen

From the Home screen, you can quickly access common features and view battery and connection status.

### Set Screen Mode

You can set up your Home screen either in Android launcher or ViewScene 3D mode. After turning on your device or pressing  , a pop-up window appears. You can select and set either Launcher or ViewScene 3D as your desired mode by default.

Launcher mode

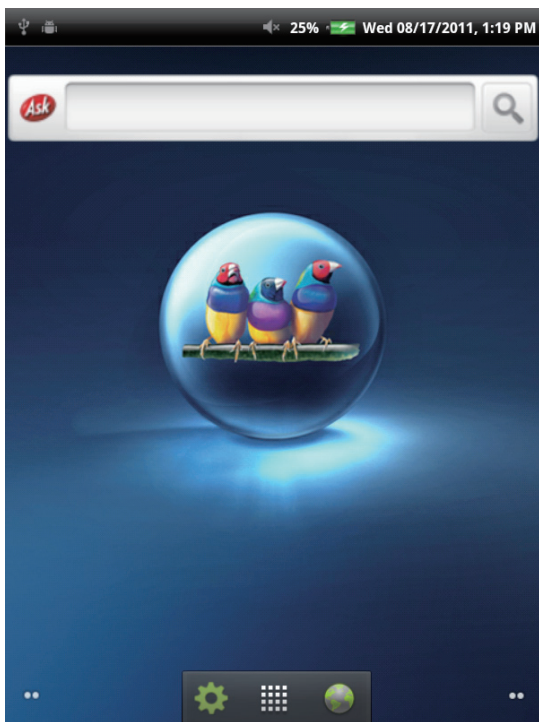

ViewScene 3D mode



### Extended Home Screen

Swipe your finger to the left or right across the Home screen.

The additional screens to the left and to the right of the Home screen provide more space for icons, widgets, shortcuts, and other items.

## Shortcut Icons

The shortcut icons allow you to easily access an application from the Home screen. You can add your favorite applications to the Home screen and arrange the icons as you desire.

### Add a shortcut icon

1. Tap and hold a blank area on the Home screen.  
Or, press **Menu** , and then tap **Add** to display the options menu.
2. Tap **Shortcuts**.

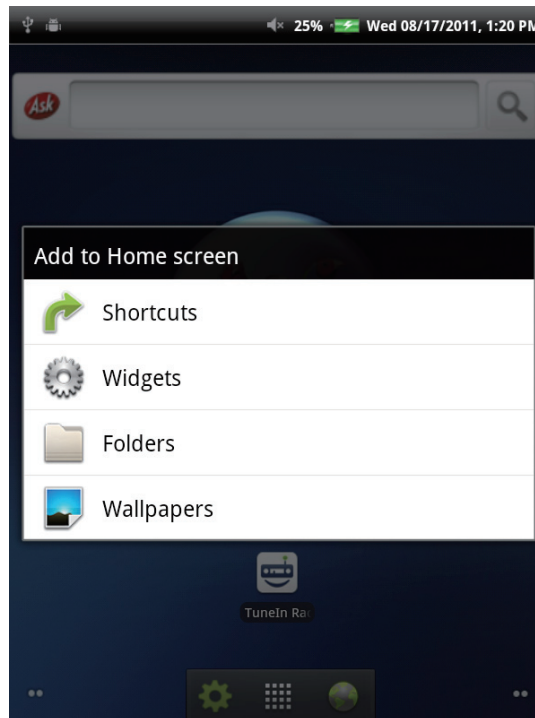



3. Tap **Applications** to display the list of applications.
4. Tap to add the items that you want to appear on the Home screen.

### Move a shortcut icon

1. Tap and hold the shortcut icon until it enlarges.
2. Drag the shortcut icon to the desired area on the Home screen.

### Remove a shortcut icon

1. Tap and hold the shortcut icon until it enlarges. The  icon appears on the bottom of the Home screen.
2. Drag the shortcut icon to  to delete.

## Widgets

Widgets allow you to receive live and personalized updates right on the Home screen. You can add, delete and move widgets just like you can with shortcut icons.

### Add a widget



You may add and customize the Widgets on the Home screen as you like.

1. Tap and hold a blank area on the Home screen.  
Or, press **Menu** , and then tap **Add** to display the options menu.
2. Tap **Widgets**.  
A list of all available widgets is displayed.
3. Tap to select the widget you want to add on the Home screen.

### Move a widget

1. Tap and hold the widget until it enlarges.
2. Drag the widget to the desired area on the Home screen.

### Remove a widget

1. Tap and hold the widget until it enlarges. The  icon appears at the bottom of the Home screen.
2. Drag the widget to  to delete.

## Applications

Tap  to view all applications and settings.

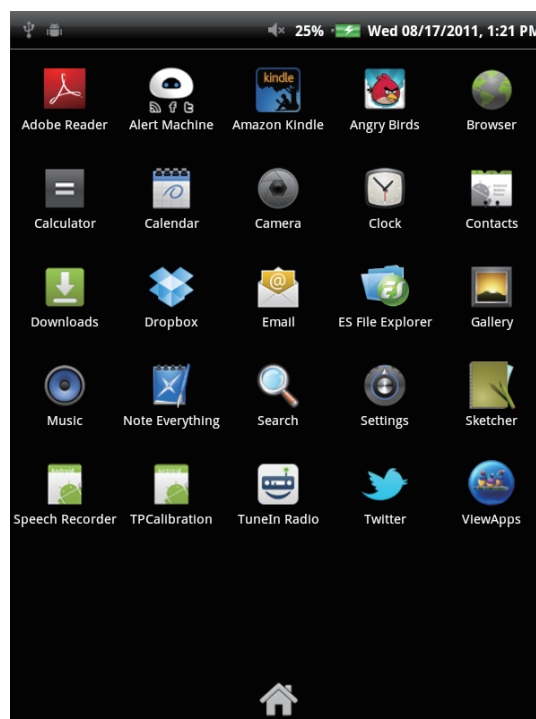

You can swipe the screen up or down to view more applications, and tap the desired icon to access the application.

Tap  to go back to Home screen.

## Setting Wallpaper

You can customize the wallpaper of your Home screen with a default wallpaper or with pictures taken with your ViewPad. Live Wallpapers are animated or interactive wallpapers.

### Set wallpaper from Live Wallpaper gallery

1. From the Home screen, press **Menu**  , and then tap **Wallpaper**. The **Select wallpaper from** is displayed on the screen.

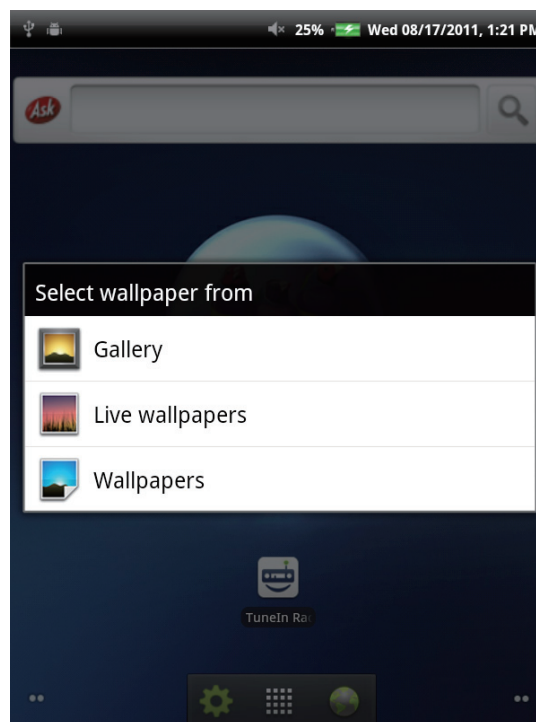

2. Tap **Live wallpapers**.
3. All default live wallpapers are displayed. Swipe your finger up or down to browse, and tap to preview the wallpaper on screen.
4. Tap **Set wallpaper** to set the previewed wallpaper as wallpaper.

### Set wallpaper from Gallery

1. From the Home screen, press **Menu**  , and then tap **Wallpaper**. The **Select wallpaper from** is displayed on the screen.
2. Tap **Gallery**.
3. You will see thumbnail images of all pictures. Tap to select the picture you want to use as wallpaper.
4. Drag your finger to select the crop area.
5. Tap **Save** to set the cropped photo as wallpaper.

## Set wallpaper from Wallpaper gallery

1. From the Home screen, press **Menu**  , and then tap **Wallpaper**. The **Select wallpaper from** is displayed on the screen.
2. Tap **Wallpapers**.
3. All default wallpapers are displayed. Swipe your finger left or right to browse and preview the wallpaper on screen.
4. Tap **Set wallpaper** to set the previewed wallpaper as wallpaper.

## 2.2 Entering Text

### On-Screen Keyboard

The on-screen keyboard appears when an application requires text input, such as writing emails and URL addresses.

#### Uppercase keyboard





#### Lowercase keyboard



## Numbers and Symbols



You can tap the keys to enter the characters, tap  or  to enter characters with upper or lower case letter, and tap  to display the numeric and symbol keyboard.

## Setting Input Method

1. Tap and hold a text field until a pop-up window appears.
2. Tap **Input method** > the desired input method.

## 2.3 Transferring Contents

You can transfer your own contents stored in your computer to the device. Before transferring, please check that your computer is using Windows 7, Windows XP, Windows Vista, or Mac OS X. You will also need a USB port on the computer.

## Making Connection

To connect your device to your computer, please follow the steps.

1. Power on your computer.
2. Plug the small end of the USB cable into the device's mini-USB port.
3. Plug the other end to your computer.

When your device is connected to computer, USB Mass Storage will appear. Press **Turn on USB storage** to go into USB drive mode.

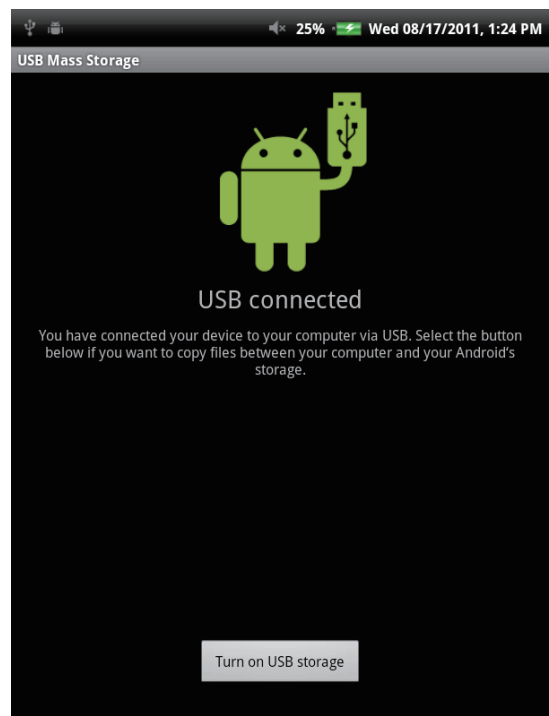

## Transferring Your Data

After going into the USB drive mode, you will see 2 disks on your computer, one is for the internal memory of your device and the other is for the Micro SD memory card inserted in the device. You can select the disk in which you'd like your documents stored.

You can add files into the device, and also can copy, move and delete files already in the device. The ViewPad 7e supports the following media formats:

Photo: JPEG, BMP, TIFF, PNG

Music: MP3, WAV

Audio: (H263/MPEG-4).3GP, WMV, Flash,(H264/MPEG-4).MP4

### NOTE

- Your device is only compatible with Windows 7, Windows XP, Windows Vista, or Mac OS X.
- If you want to continue using your device, you need to release it from USB drive mode by un-mounting the device from your computer.



## Chapter 3: Using Email

You can use your device to send and receive email messages via your internet email accounts just as you do with a computer.

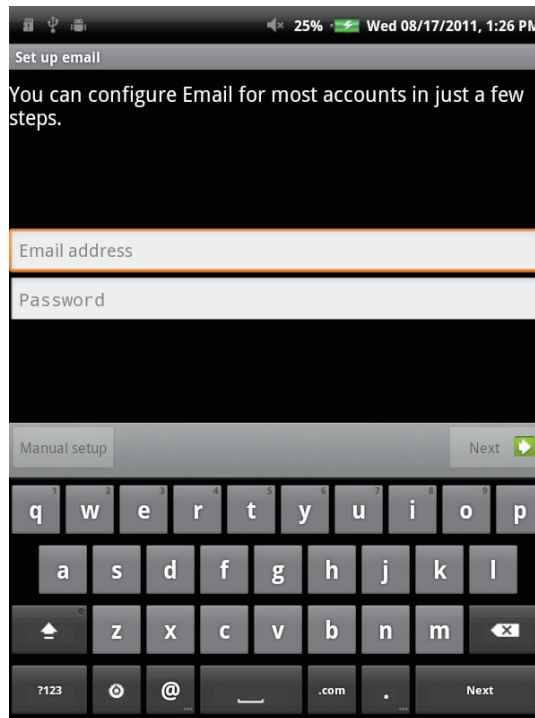

### 3.1 Setting up an Internet Email Account

1. On the Home screen, tap  > **Email**.
2. Enter your **email address** and **password** in its respective entry box.



3. Tap **Next**.
4. Enter your **email account** name and **password**.
5. Tap **Done**.

### 3.2 Composing and Sending an Email

1. On the Home screen, tap  > **Email**.
2. Enter your email account and password to login in.
3. Press **Menu**  and then tap **Compose**.
4. Enter the recipient's email address, subject and your email content.
5. Tap **Send**.

You can add your attachment to your email by pressing **Menu**  and then tapping **Add attachment** to select the desired files.

### 3.3 Receiving an Email

Emails are automatically received in your Inbox when the device connects to a wireless network.

1. On the Home screen, tap  > **Email**.
2. Enter your email account and password to log in.
3. Tap a message to view its content.

You can view email attachment by tapping **Open** or download it by tapping **Save**.

# Chapter 4: Using Internet

## 4.1 Setting up Wi-Fi

This device only uses Wi-Fi connection. You need to connect to a wireless network before surfing the internet or using the related applications that require internet connection.

### To turn Wi-Fi on or off

1. From the Home screen, tap  > **Settings** > **Wireless & networks**.
2. Tap **Wi-Fi** check box to turn Wi-Fi function on or off.

### To connect to a Wi-Fi network

1. Turn Wi-Fi on.
2. Tap **Wi-Fi settings** > **Network notification** to start detecting networks.
3. The available networks are listed. Tap a network to connect to or tap **Add Wi-fi network** to manually add a connection.
4. If you select an unsecured network, the connection is automatically established. Otherwise, proceed to the next step.
5. When connecting to a secured network, you will be prompted for the password. Enter the password, then tap **Connect**.

When Wi-Fi is connected, the connection icon is displayed on the status bar.

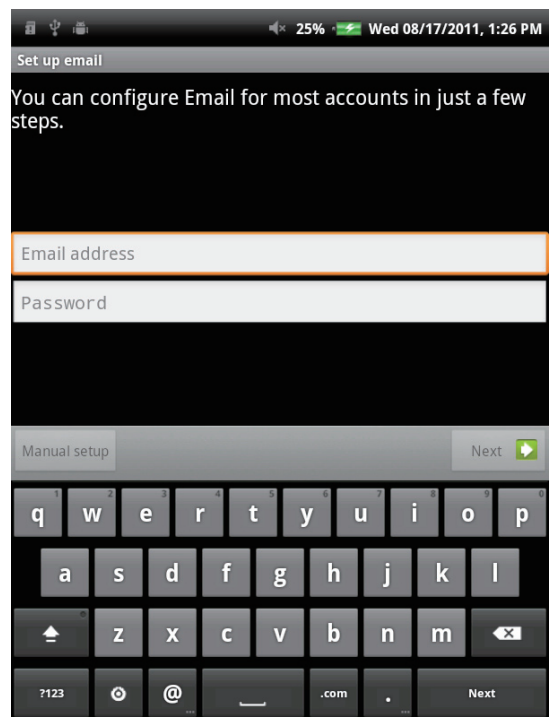

### To add Wi-Fi network

1. From the Home screen, tap  > **Settings** > **Wireless & networks**.
2. Tap **Wi-Fi settings**.
3. In Wi-Fi networks, tap **Add Wi-Fi network**. A new window is displayed.
4. Follow the on-screen instructions and enter the necessary information, then tap **Save** to save the settings.



## 4.2 Accessing the Web

Your device allows you to access any internet web.

1. On the Home screen, tap  or  > **Browser**.
2. Tap the text field, and the keyboard pops up.

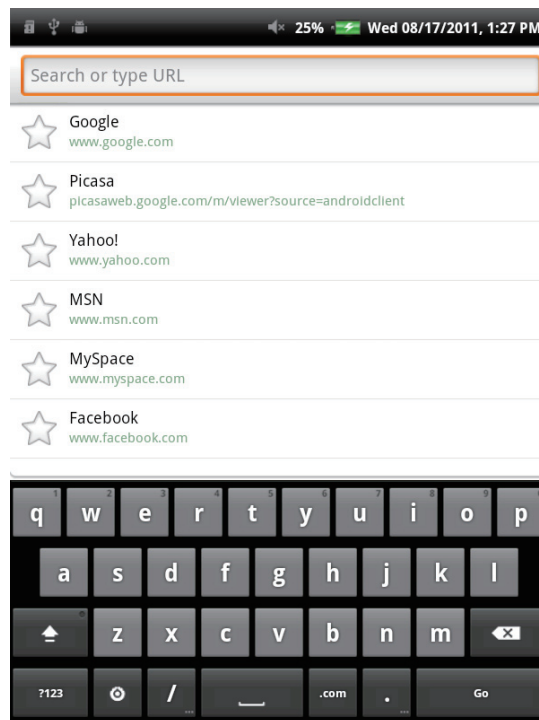

3. Enter the URL, and then tap **Go** to enter the website.
4. Scroll the page up or down to view more information.

If you want the current page as your home page while browsing the web, please press **Menu**  , and then tap **More** > **Settings** > **Set home page**.

# Chapter 5: Using Bluetooth

## Bluetooth modes

**On:** Bluetooth is turned on. Your ViewPad detects other Bluetooth devices, but your device is not visible to others.

**Discoverable:** Bluetooth is turned on and your device is visible to other Bluetooth devices.

**Off:** Bluetooth is turned off.

## To turn Bluetooth on or off

1. From the Home screen, tap  > **Settings** > **Wireless & networks**.
2. Tap **Bluetooth** check box to activate the Bluetooth function.
3. To make your ViewPad visible to others, tap **Bluetooth settings** > **Discoverable** check box to make this device visible to other devices.

## 5.1 Connecting to Bluetooth Devices

A connection to a Bluetooth device is called a partnership. You need to pair and create a partnership with a Bluetooth device to exchange information.

- 1 From the Home screen, tap  > **Settings** > **Wireless & networks**.
2. Tap **Bluetooth settings** to view the menu options.
3. To search for a new device, tap **Scan for devices**.
4. Tap a device to connect.
5. To start pairing, enter the **Passcode**, then tap **OK**.
6. The paired bluetooth device name is displayed.
7. Tap **Done**.

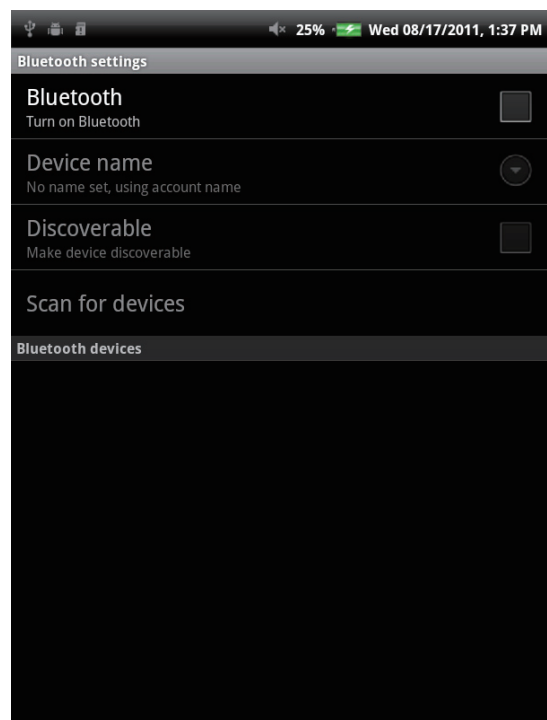

### NOTE:

- The passcode to be entered must be the same passcode entered on the other Bluetooth device.
- Once a partnership has been created, connecting to that device again will no longer require entering the passcode.

# Chapter 6: Searching on Device

Your device allows you to take advantage of powerful search capabilities for searching documents and apps on your device, as well as searching the web.

## 6.1 Searching Contents on Device

1. On the Home screen, tap  > **Search**.
2. Enter the key words or phrase in the text field.
3. Tap **Go** to start searching.

## 6.2 Searching the Web



1. On the Home screen, tap  > **Search**.
2. Enter the URL address in the text field.
3. Tap **Go** to start searching.

# Chapter 7: Multimedia Applications





## 7.1 Taking Photos and Videos

Your device is equipped with a 0.3 megapixels front camera and a 3.0 megapixels main camera for you to take photos and record videos.

### Taking a Photo

1. On the Home screen, tap  > **Camera**.
2. Aim the device at the desired subject.
3. Tap  to take the photo.

### Recording a Video

1. On the Home screen, tap  > **Camera**.
2. Tap  to go to the video mode.
3. Aim the device at the desired subject.
4. Tap  to start recording, and tap  to stop recording.

### Configuring Camera Settings

You can adjust the settings when you take photos or videos. Tap the icon to access the respective menu, and scroll the bar to view more options.

Mode	Mode Settings	Available options
Photo Mode	White Balance	Auto, Incandescent, Daylight, Fluorescent, Cloudy
	Exposure	+2, +1, 0, -1, -2
	Picture size	2048×1536, 1600×1200, 1024×768, 800×600, 640×480
	Picture quality	Super fine, Fine, Normal
	Color effect	None, Mono, Sepia, Negative
	Camera settings	Restore defaults
Video Mode	Video quality	High, Low, MMS, YouTube
	White Balance	Auto, Incandescent, Daylight, Fluorescent, Cloudy
	Color effect	None, Mono, Sepia, Negative
	Camera settings	Restore defaults

## 7.2 Playing Photos and Videos

The photos and videos you took or recorded are saved in the respective folder categories in **Gallery** by default.

### Viewing Photos

1. On the Home screen, tap  > **Gallery**.
2. Tap **Photos** to view the images in thumbnails.
3. Tap an image to view it in full screen.
4. Swipe your finger to left or right to view the previous or next image.

Tap **Slideshow**, the images will play one by one automatically in slideshow mode. And if you want to share, edit or delete the image, please tap **Menu** and then select the desired option.

### Playing Videos

1. On the Home screen, tap  > **Gallery**.
2. Tap **Videos** to display all saved videos.

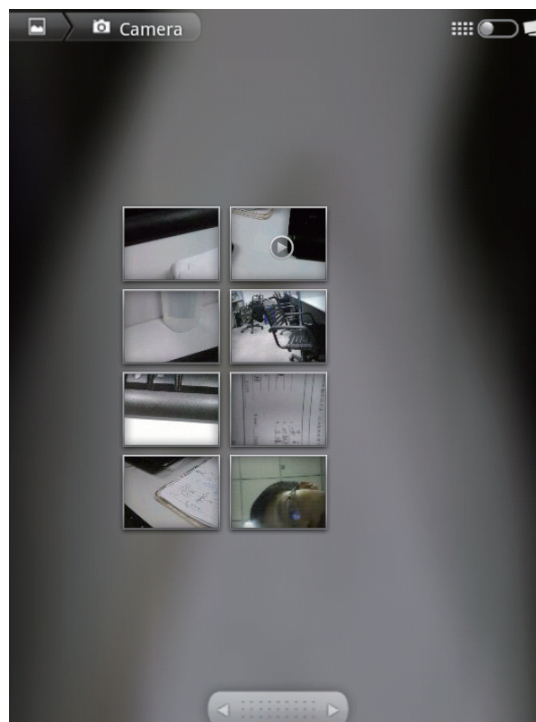

3. Tap a video to start playing.





## 7.3 Playing Music

You can play the music stored in your device or Micro SD card inserted.

### Playing Music

1. On the Home screen, tap  > **Music**.
2. Select the desired track from the **Songs** list or **Playlists** to play it.
3. Press the Volume button to increase or decrease the playing sound.

During playing, you can press **Menu**  to add it to the desired playing list or delete it.

Item	Description
	To play the track
	To pause the track
	Play the previous track
	Play the next track
Process bar	Play forward or backward
	To view the playing list
	Turn on or off shuffle
	Repeat the current song or all songs, or turn off repeat

### NOTE

You can leave the playing screen and browsing other pages without stopping the playing.

### Managing Playlist

You can add any songs to your preferred playlist.

1. On the Home screen, tap  > **Music**.
2. Tap and hold the desired track until a pop-up window appears.
3. Tap **Add to playlist**, and then select **Current playlist** or **New** to save.

If you select **New**, you need to enter the playlist name and then tap **Save** to create a new playlist.

# Chapter 8: Applications

## 8.1 Email

Use your device to send and receive email messages via your internet email accounts just as you do with a computer.

## 8.2 Browser

Browse web pages on your device, and bookmark your desired pages.

## 8.3 Camera

Your device has two cameras, and you can take photos and videos by using the camera either on the front or back of your device.

## 8.4 Music

You can enjoy your music stored in your SD on your device.

## 8.5 Gallery

You can enjoy your photos taken by yourself or stored in your SD on your device.

## 8.6 Sound Recorder

You can enjoy your sound recorded by yourself on your device.

## 8.7 Amazon Kindle

Buy and read your e-books from Amazon Kindle. Log in with your Amazon account to read your Kindle e-books or browse and download new ones.

## 8.8 Amazon Appstore

Amazon Appstore for Android offers instant download of thousands of free and premium apps for communication, entertainment and more. Simply sign in with your Amazon account. (Currently only available in the USA.)

## 8.9 Amazon MP3

Amazon MP3 includes the Amazon MP3 store and cloud player. Browse, preview and listen to your favorite music, whether stored on your SD card or in your Amazon Cloud Drive. (Currently only available in the USA.)

## **8.10 Calculator**

Perform basic arithmetic functions, such as addition, subtraction, multiplication, and division on your device.

## **8.11 Calendar**

Create and track schedule or appointments on your device.

## **8.12 Clock**

Set up alarms on your device.

## **8.13 Search**

Search information in your device and websites by using your device.

## **8.14 Downloads**

View and delete the files you have downloaded from the web pages.

## **8.15 ES File Explorer**

View, delete and manage the files stored on your device and SD card with this full featured file explorer. You can also install, backup, and uninstall applications.

## **8.16 Alert Machine**

Alert Machine delivers updates from your favorite social networks and news channels right to your notifications bar or Home screen widget.

## **8.17 Dropbox**

DropBox gives you 2GB of free cloud storage. Access all your important documents, media files and more, anywhere, right from your ViewPad. If you don't have a DropBox account, you can create one easily for free the first time you launch the app.

## **8.18 Note Everything**

This full-featured note taking app makes it easy to create, view and manage text notes, as well as hand-drawn notes and voice recordings.

## 8.19 Sketcher

Create beautiful drawings with the sketchpad app, featuring a variety of textured brushes and colors.

## 8.20 Tunein Radio

Listen to your favorite AM/FM and Internet radio stations from around the globe. You can browse by category, genre or location, search for artists, and bookmark your favorite stations.

## 8.21 Twitter

The official Twitter client for Android keeps you connected to your friends and followers on the popular social networking service.

## 8.22 Settings

View and adjust the settings of your device. Settings menu is categorized into: Wireless & networks, Sound, Display, Location & security, Applications, Accounts & Sync, Privacy, Storage, Language & keyboard, Voice input & output, Accessibility, Date & Time, and About device.

## 8.23 FW Update

Check if a new firmware is available for your device and perform the system update. Please refer to the screen instruction to manually start the firmware update.

### **NOTE**

Please make sure that your device has at least 30% battery power or the AC adapter is plugged in during FW update.

# Chapter 9: Managing Your Device

From the Home screen, tap  > **Settings** to view and adjust the settings of your ViewPad. Settings menu is categorized into: **Wireless & networks**, **Sound**, **Display**, **Location & security**, **Applications**, **Accounts & sync**, **Privacy**, **Storage**, **Language & keyboard**, **Voice input & output**, **Accessibility**, **Date & time**, and **About device**.

## 9.1 Wireless & networks

Application	Description
Wi-Fi settings	Manage Wi-Fi connections, scan and connect to available Wi-Fi networks
Bluetooth settings	Manage connections, set device name, and discoverability of the device

## 9.2 Sound

Application	Description
Silent mode	Turn silent mode on or off. All sounds except media and alarms are turned off
Volume	Adjust the volume for ringtone, media, and alarms
Audible touch tones	Enable or disable sound when using dial pad
Audible selection	Enable or disable sound when making screen selection
Screen lock sounds	Play sounds when locking or unlocking the screen
Haptic feedback	Play sound when pressing soft keys and on certain UI interactions

## 9.3 Display

Application	Description
Brightness	Adjust the brightness of the screen
Auto-rotate screen	Switch orientation automatically when rotating the device
Animation	Show animation when opening and closing windows
Screen timeout	Adjust delay before the screen automatically goes off
TV Mode	Choose TV out mode
TV Resolution	Choose TV resolution

## 9.4 Location & security

Application	Description
Use wireless networks	Allow location to be determined by Wi-Fi or mobile networks
Set up screen lock	Set the lock screen with a pattern, PIN, or password
Visible passwords	Show password as you type
Select device administrators	Add or remove device administrators
Use secure credential	Allow applications to access secure certificates and other credentials
Install from SD card	Install encrypted certificated from SD card
Set password	Set or change the credential storage password
Clear storage	Clear credential storage of all contents and reset its password

## 9.5 Applications

Application	Description
Unknown sources	Allow install of non-market applications
Manage applications	Manage and remove installed applications
Running services	View and control currently running services
Storage use	View storage used by applications
Battery use	What has been using the battery
Development	Set options for application development

## 9.6 Accounts & sync

Application	Description
Background data	Applications can sync and receive data at any time
Auto-sync	Applications sync data automatically

## 9.7 Privacy

Application	Description
Factory data reset	Erases all data on device

## 9.8 Storage

Application	Description
Format SD card	Format SD card
Internal device storage	Show available device storage

## 9.9 Language & Keyboard

Application	Description
Select language	Set the on-screen display language for your device
Touch Pal	Configure on-screen keyboard settings

## 9.10 Voice input & output

Application	Description
Text-to-speech settings	Set the text-to-speech settings

## 9.11 Accessibility

Application	Description
Accessibility	Configure the settings for the downloaded application with an accessibility feature.

## 9.12 Date & time

Application	Description
Automatic	Check to use network provided values
Set date	Set the date
Set time zone	Select the time zone of your current location
Set time	Set the time
Use 24-hour format	Set the clock to 24-hour format
Select date format	Set the preferred date format

## 9.13 About device

Check the system update and view device status, battery usage, legal information, model number, and software version.

# Specifications

## Screen

Aspect Ratio	4:3
Resolution (Pixels)	800x600

## Connectivity

USB	USB 2.0
Wi-Fi	802.11 b/g/n
Bluetooth	2.1with EDR

## Power

Battery	3300mAh, 3.7V. rechargeable battery
AC Adapter	Input power: 100-240V Output power: 5V/2 A Model: PSAA10R-050YYY(Y=0-9, A-Z, blank or alphanumeric) Trade mark: PHIHONG

## Memory card

Internal memory	eMMC iNand 4GB
External memory	Micro SD

## File Formats

Photo	JPEG, BMP, TIFF, PNG
Music	MP3, WAV
Audio	(H263/MPEG-4).3GP, WMV, Flash,(H264/MPEG-4).MP4

## Temperature

Operating	0~40°C
Storage	-30~65°C



# Customer Support

For technical support or product service, see the table below or contact your reseller.

**NOTE:** You will need the product serial number.

Country/Region	Website	T = Telephone F = FAX	Email
Australia/New Zealand	www.viewsonic.com.au	AUS= 1800 880 818 NZ= 0800 008 822	service@au.viewsonic.com
Canada	www.viewsonic.com	T (Toll-Free)= 1-866-463-4775 T (Toll)= 1-424-233-2533 F= 1-909-468-3757	service.ca@viewsonic.com
Europe	www.viewsoniceurope.com	www.viewsoniceurope.com/uk/support/call-desk/	
Hong Kong	www.hk.viewsonic.com	T= 852 3102 2900	service@hk.viewsonic.com
India	www.in.viewsonic.com	T= 1800 266 0101	service@in.viewsonic.com
Ireland (Eire)	www.viewsoniceurope.com/uk/	www.viewsoniceurope.com/uk/support/call-desk/	service_ie@viewsoniceurope.com
Korea	www.kr.viewsonic.com	T= 080 333 2131	service@kr.viewsonic.com
Latin America (Argentina)	www.viewsonic.com/la/	T= 0800-4441185	soporte@viewsonic.com
Latin America (Chile)	www.viewsonic.com/la/	T= 1230-020-7975	soporte@viewsonic.com
Latin America (Columbia)	www.viewsonic.com/la/	T= 01800-9-157235	soporte@viewsonic.com
Latin America (Mexico)	www.viewsonic.com/la/	T= 001-8882328722	soporte@viewsonic.com
Renta y Datos, 29 SUR 721, COL. LA PAZ, 72160 PUEBLA, PUE. Tel: 01.222.891.55.77 CON 10 LINEAS Electroser, Av Reforma No. 403Gx39 y 41, 97000 Mérida, Yucatán. Tel: 01.999.925.19.16 Other places please refer to <a href="http://www.viewsonic.com/la/soporte/index.htm#Mexico">http://www.viewsonic.com/la/soporte/index.htm#Mexico</a>			
Latin America (Peru)	www.viewsonic.com/la/	T= 0800-54565	soporte@viewsonic.com
Macau	www.hk.viewsonic.com	T= 853 2870 0303	service@hk.viewsonic.com
Middle East	ap.viewsonic.com/me/	Contact your reseller	service@ap.viewsonic.com
Puerto Rico & Virgin Islands	www.viewsonic.com	T= 1-800-688-6688 (English) T= 1-866-379-1304 (Spanish) F= 1-909-468-3757	service.us@viewsonic.com soporte@viewsonic.com
Singapore/Malaysia/Thailand	www.ap.viewsonic.com	T= 65 6461 6044	service@sg.viewsonic.com
South Africa	ap.viewsonic.com/za/	Contact your reseller	service@ap.viewsonic.com
United Kingdom	www.viewsoniceurope.com/uk/	www.viewsoniceurope.com/uk/support/call-desk/	service_gb@viewsoniceurope.com
United States	www.viewsonic.com	T (Toll-Free)= 1-800-688-6688 T (Toll)= 1-424-233-2530 F= 1-909-468-3757	service.us@viewsonic.com

# Limited Warranty

## VIEWSONIC® ViewPad

### **What the warranty covers:**

ViewSonic warrants its products to be free from defects in material and workmanship, under normal use, during the warranty period. If a product proves to be defective in material or workmanship during the warranty period, ViewSonic will, at its sole option, repair or replace the product with a like product. Replacement product or parts may include remanufactured or refurbished parts or components. The replacement unit will be covered by the balance of the time remaining on the customer's original limited warranty. ViewSonic provides no warranty for the third-party software included with the product or installed by the customer.

### **How long the warranty is effective:**

ViewSonic ViewPad are warranted for at least 1 year for labor from the date of the first customer purchase.

User is responsible for the back up of any data before returning the unit for service.

ViewSonic is not responsible for any data lost.

### **Who the warranty protects:**

This warranty is valid only for the first consumer purchaser.

### **What the warranty does not cover:**

1. Any product on which the serial number has been defaced, modified or removed.
2. Damage, deterioration or malfunction resulting from:
  - a. Accident, misuse, neglect, fire, water, lightning, or other acts of nature, unauthorized product modification, or failure to follow instructions supplied with the product.
  - b. Repair or attempted repair by anyone not authorized by ViewSonic.
  - c. Causes external to the product, such as electric power fluctuations or failure.
  - d. Use of supplies or parts not meeting ViewSonic's specifications.
  - e. Normal wear and tear.
  - f. Any other cause which does not relate to a product defect.
3. Any product exhibiting a condition commonly known as "image burn-in" which results when a static image is displayed on the product for an extended period of time.
4. Removal, installation, insurance, and set-up service charges.

### **How to get service:**

1. For information about receiving service under warranty, contact ViewSonic Customer Support (Please refer to the web site and Customer Support pages). You will need to provide your product's serial number.
2. To obtain warranty service, you will be required to provide (a) the original dated sales slip, (b) your name, (c) your address, (d) a description of the problem, and (e) the serial number of the product.
3. Take or ship the product freight prepaid in the original container to an authorized ViewSonic service center or ViewSonic.
4. For additional information or the name of the nearest ViewSonic service center, contact ViewSonic.

**Limitation of implied warranties:**

There are no warranties, express or implied, which extend beyond the description contained herein including the implied warranty of merchantability and fitness for a particular purpose.

**Exclusion of damages:**

ViewSonic's liability is limited to the cost of repair or replacement of the product. ViewSonic shall not be liable for:

1. Damage to other property caused by any defects in the product, damages based upon inconvenience, loss of use of the product, loss of time, loss of profits, loss of business opportunity, loss of goodwill, interference with business relationships, or other commercial loss, even if advised of the possibility of such damages.
2. Any other damages, whether incidental, consequential or otherwise.
3. Any claim against the customer by any other party.
4. Repair or attempted repair by anyone not authorized by ViewSonic.

**Effect of state law:**

This warranty gives you specific legal rights, and you may also have other rights which vary from state to state. Some states do not allow limitations on implied warranties and/or do not allow the exclusion of incidental or consequential damages, so the above limitations and exclusions may not apply to you.

**Sales outside the U.S.A. and Canada:**

For warranty information and service on ViewSonic products sold outside of the U.S.A. and Canada, contact ViewSonic or your local ViewSonic dealer. The warranty period for this product in mainland China (Hong Kong, Macao and Taiwan Excluded) is subject to the terms and conditions of the Maintenance Guarantee Card.

For users in Europe and Russia, full details of warranty provided can be found in [www.viewsoniceurope.com](http://www.viewsoniceurope.com) under Support/Warranty Information.



**ViewSonic®**